



COMFORT MAX™ BELT PACK

Inflatable *Personal Flotation Device (PFD)* **OWNER'S MANUAL**

Model 61098
Manual Inflation
USCG Approved Type III PFD

This manual contains important information. Read it!

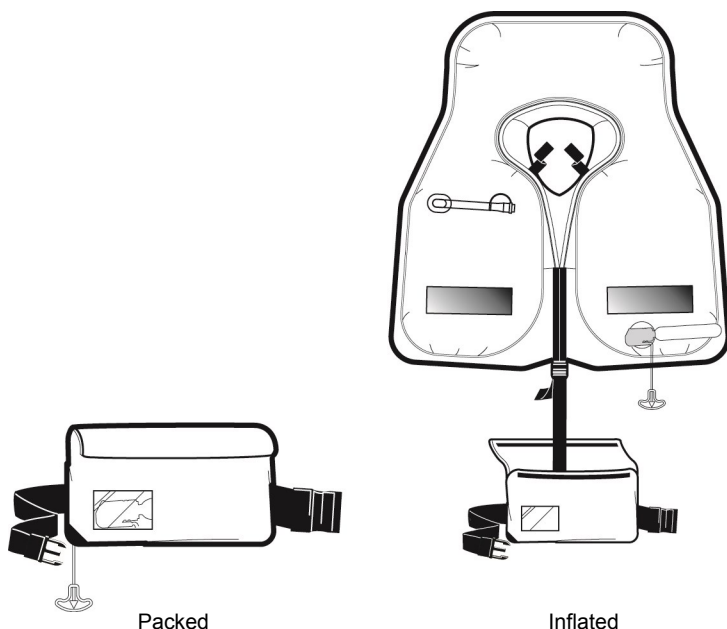

Keep this book and the sales receipt together in a safe place for future reference.
Please record your PFD's model's information:

Lot Number: _____ Purchase Date: _____ Retailer: _____

DO NOT REMOVE THIS PAMPHLET PRIOR TO SALE

TABLE OF CONTENTS

1.0	Personal Flotation Device Safety	Pg. 3
2.0	Approval Conditions and Carriage Regulations	Pg. 3
3.0	Mandatory Carriage Requirements	Pg. 3
4.0	Parts and Features	Pg. 4
5.0	About Your PFD	Pg. 5
6.0	Instructions for Use	Pg. 6
6.1	Pre-Donning Inspection	Pg. 6
6.1.1	Check for Green "OK" Service Indicator	Pg. 6
6.1.2	Check Manual Pull Tab Access	Pg. 6
6.1.3	Basic Visual Inspection for Damage	Pg. 6
6.2	Putting on Your PFD (Donning)	Pg. 7
6.3	Inflating by Using the CO2 Inflator Mechanism	Pg. 8
6.4	Inflating by Mouth (Oral Inflation)	Pg. 8
6.5	Deflating Your PFD	Pg. 8
6.6	Use Below Freezing	Pg. 8
6.7	Rearming the CO2 Inflator Mechanism	Pg. 9
6.8	Refolding Your PFD	Pg. 12
7.0	Is Your PFD in Good and Serviceable Condition?	Pg. 14
8.0	Care and Maintenance Instructions	Pg. 14
8.1	Service Test Procedures	Pg. 14
8.1.1	Visual Inspection	Pg. 14
8.1.2	Leakage Test	Pg. 14
8.2	Cleaning	Pg. 14
8.3	Storage	Pg. 14
8.4	Professional Servicing	Pg. 15
9.0	Why are PFD's Required Safety Equipment?	Pg. 15
10.0	How and Why Do You Test Your PFD?	Pg. 16
10.1	How Do You Test Your PFD Using the Manual Inflator?	Pg. 16
10.2	How Do You Test Your PFD Using the Oral Inflator?	Pg. 17
11.0	Wear Your PFD	Pg. 17
12.0	Hypothermia	Pg. 18
13.0	Each of These Devices is Intended to Help You Save Your Own Life	Pg. 19
14.0	Additional Information	Pg. 19
14.1	Do Not Attach PFD's to Your Boat	Pg. 19

1.0 Personal Flotation Device Safety

- This Personal Flotation Device (PFD) does not provide any buoyancy unless inflated. You must inflate the PFD to float.
- Never inflate the PFD by mouth first and then pull the handle. Doing so may over inflate and damage the inflatable cell.
- Each CO₂ cylinder will only inflate the PFD once. The PFD must be re-armed with a new CO₂ cylinder after each use.
- Do not dry clean, iron or machine wash your PFD.
- Do not use the PFD in weather below freezing temperature (32°F / 0°C), unless partially inflated.
- Inflatable devices filled with carbon dioxide (CO₂) deflate faster than those filled with air. You will have to replenish the cell sooner and more often with oral tube.
- Do not use damaged PFDs. Discard them, or return to REVERE for repair.
- Do not use on personal watercraft, or for water skiing, knee boarding or similar uses.

2.0 Approval Conditions and Carriage Regulations

This inflatable PFD is approved by the U.S. Coast Guard for use as a Type III Personal Flotation Device (PFD).

This inflatable was designed to be more comfortable and less restrictive to wear than inherently buoyant PFD's. It is not approved for water skiing or other high impact, high-speed activities. When worn, used, and serviced according to this owner's manual, this PFD can greatly increase your chances of survival in the water. Not recommended for non-swimmers or weak swimmers. Users of inflatable PFDs must be at least 16 years old.

3.0 Mandatory Carriage Requirements

Federal regulations in 33 CFR 175-1993 require you to carry Coast Guard approved personal flotation devices (PFDs) legibly marked with the Coast Guard approval number which are in good and serviceable condition and are the correct size for each person on board. To be considered serviceable, this PFD shall not exhibit deterioration that could diminish its performance such as broken or deformed hardware, detached webbing, rotted structural components, air leaks, or nonfunctional oral inflation tube. Unless worn, this PFD must also be properly armed with a full CO₂ cylinder, inflation system status indicator, and an accessible manual inflation lanyard. A PFD which is "approved only when worn" or "required to be worn" must be worn under the specified conditions.

4.0 Parts and Features

The REVERE COMFORT MAX™ BELT PACK PFD is designed for adults weighing more than 80 lbs. (36 kg) with chest sizes between 30 inches (76 cm) and 52 inches (132 cm) in circumference.

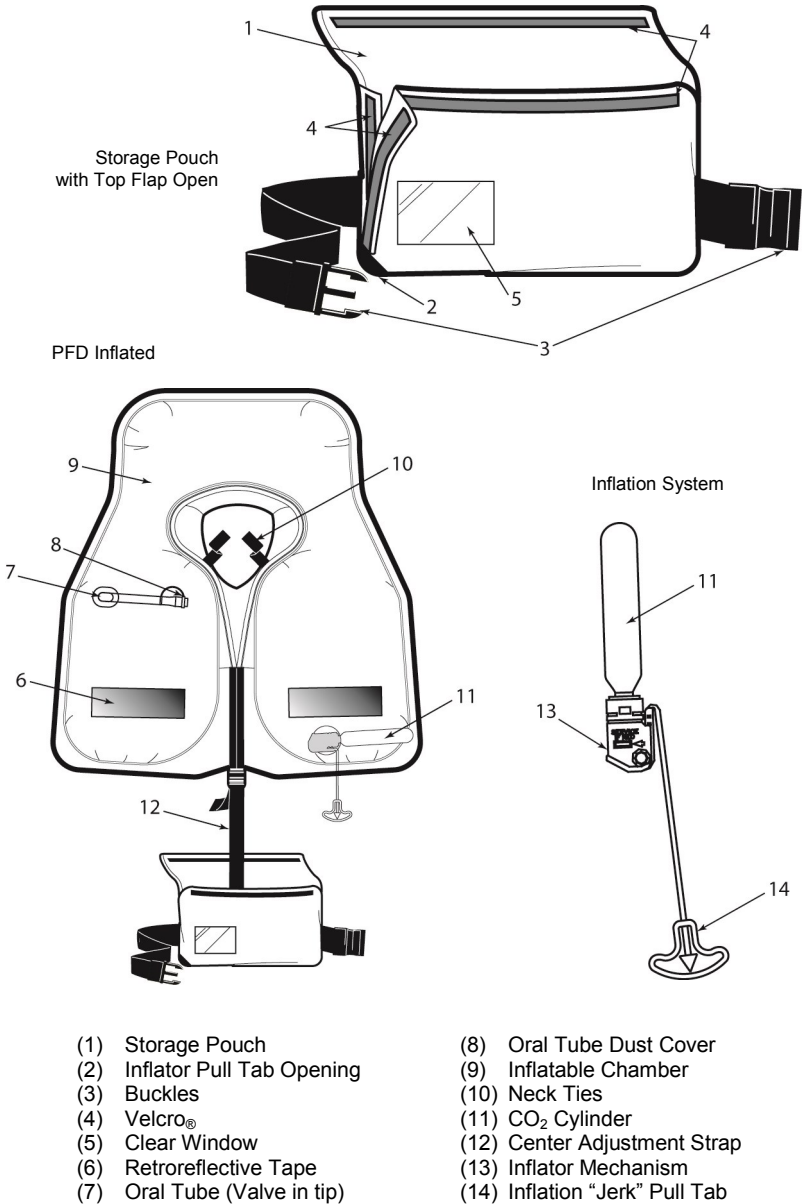

Figure 1

5.0 About Your PFD

Your REVERE COMFORT MAX™ BELT PACK inflatable personal flotation device (PFD) consists of an inflatable air-holding chamber, an inflation system, and a storage pouch. The PFD is designed to be lightweight and comfortable so it can be worn deflated and around your waist while on your boat. The storage pouch keeps the deflated chamber packed securely allowing you to perform activities without interference. The PFD provides no buoyancy unless it is inflated.

Model 61098 is a manually activated PFD. It has a carbon dioxide (CO₂) cylinder and its activating mechanism, as well as an oral tube to blow air into the chamber in the event of failure of the inflator mechanism. The PFD is inflated by pulling down hard on the yellow handle marked "JERK" on the right hand side of the pouch. This causes the PFD's CO₂ inflation mechanism to puncture a self-contained carbon dioxide cylinder and discharge this harmless gas into the inflatable chamber. The chamber then inflates and bursts from the storage pouch. You do **NOT** need to open the pouch or remove the chamber.

Once out of the pouch, the inflated chamber is placed over your head and worn about your neck. It can be adjusted to fit the wearer by using the center adjustment strap. The oral inflation tube provided can be used for topping the PFD off by mouth. After use, the inflation system can be rearmed, a new CO₂ cylinder installed, and the PFD can be repacked to be used again and again.

The PFD is also equipped with retro-reflective tape panels for better visibility at night.

6.0 Instructions for Use

6.1 Pre-Donning Inspection

Each time before you put on your PFD, follow the steps in Sections 6.1.1 through 6.1.3 to check the condition of your PFD.

6.1.1 Check for Green "OK" Service Indicator

Look through the clear plastic window on the front of the belt pack to view the service indicator on the inflator. Refer to Figure 2. The indicator must be GREEN to show a properly armed mechanism. If the service indicator is RED, rearm the mechanism per the instructions in Section 6.7, *Rearming the CO₂ Inflator Mechanism*.

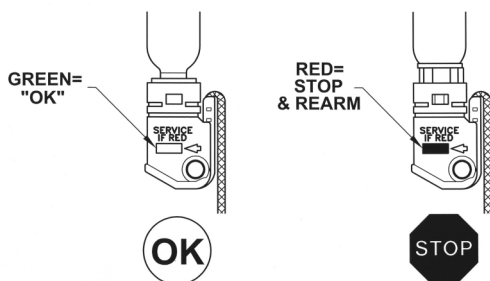

Figure 2

6.1.2 Check Manual Pull Tab Access

Check that the yellow "JERK" tab is hanging through the cutout hole of the belt pack.

6.1.3 Basic Visual Inspection for Damage

Visually examine the Inflatable PFD for damage or excessive abrasion, fading, wear, tear, or contamination. Particular attention must be paid to the seams, stitching, straps and webbing attachments, hardware (buckles and slides), etc. Check for strength by pulling seams and attachments snugly. Make sure that the PFD and inflation chamber is not twisted and is free from rips, tears, or punctures. If PFD shows any signs of damage, perform a Leak Test, or send it to an authorized repair facility or replace the entire device.

WARNING: DO NOT USE DAMAGED PFD'S. DISCARD THEM, OR RETURN TO REVERE FOR REPAIR.

6.2 Putting on Your PFD (Donning)

Put the PFD is worn about your waist like a belt. Refer to Figure 3. Buckle it at the left side of the pouch and and tighten the waist strap. The yellow “JERK” pull tab for the inflation mechanism protrudes from an opening on the right side of the storage pouch. Check its location by hand and know where it is.

Step 1 Ⓐ Put belt around your waist and buckle on your left side. Ⓑ Adjust free end of belt until snug.

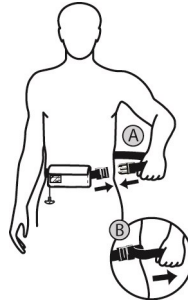

Step 2 Pull yellow “JERK” tab down to inflate.

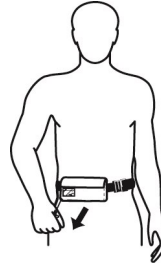

Step 3 Ⓒ Pull inflated PFD over head with oral tube facing away from body. Ⓓ Tighten center adjustment strap snugly to ensure PFD remains secure on your head when jumping into the water.

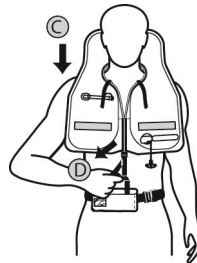

Step 4 Tie neck straps in a knot as tight as possible.



Figure 3

6.3 Inflating by Using the CO₂ Inflater Mechanism

To manually inflate the PFD instantly, pull sharply in a downward direction on the yellow handle marked "JERK" to discharge the CO₂ cylinder.

WARNING: INFLATABLE DEVICES DEFLATE GRADUALLY DUE TO PERMEATION LOSSES THROUGH THE MATERIAL OF THE CELL. THESE LOSSES ARE GREATER WHEN THE DEVICE IS INFLATED WITH CARBON DIOXIDE (CO₂) THAN WITH AIR. THEREFORE, EARLIER REPLENISHMENT BY MEANS OF THE ORAL INFLATION SYSTEM WILL BE NECESSARY.

6.4 Inflating by Mouth (Oral Inflation)

To inflate the PFD orally, flip the replaceable black dust cap off from the top of the red oral tube and blow air into the oral tube (see Figure 4) until the PFD is firm. To make oral inflation easier, open the Velcro closures of the PFD and unfold. Practice this procedure a few times until you are confident how to orally inflate your PFD. Replace the dust cap on top of the oral tube when you are done.

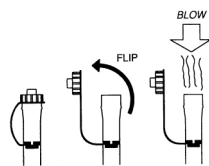

Figure 4

Occasionally, dust particles get trapped in the oral valve, causing it to leak slightly. Blowing into the valve and/or tapping on the valve with a finger will usually clear the dust and stop the leak. Keep the dust cap in place at all times.

6.5 Deflating Your PFD

Remove the black dust cap from the top of the red oral tube. Twist the dust cap around and insert the small topside of the dust cap into the oral tube. Hold in place to keep the valve open (see Figure 5). At the same time, squeeze the PFD to force all the gas out through the oral valve until the PFD is fully evacuated and flat.

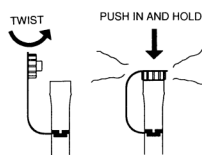

Figure 5

6.6 Use Below Freezing

When the PFD is used in weather below freezing temperature (32°F / 0°C), it should be partially inflated by mouth. At these lower temperatures, the inflation time is longer using only the CO₂ inflater mechanism. A partially inflated device will provide initial buoyancy while the PFD inflates.

Under cold weather conditions, CO₂ inflation may not be adequate. Additional oral inflation may be needed after inflation.

6.7 Rearming the CO₂ Inflator Mechanism

Each time the CO₂ inflation mechanism on your PFD is actuated, the inflator must be rearmed (reset) and the empty CO₂ cylinder replaced. All the necessary parts are included in the rearming kits available from your local REVERE retailer.

Follow the Steps 1 thru 7 shown in Figures 6A and 6B.

Parts Required: One (1) REVERE Rearming Kit 61026. This kit contains a replacement cylinder and bayonet assembly.

Step 1

Open the Belt Pack and remove chamber. Spread chamber out so that the manual inflator and cylinder are visible.

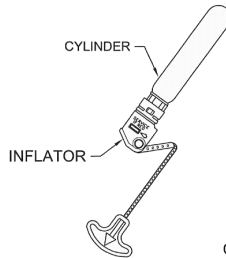

Step 2

Remove the old cylinder & bayonet assembly by rotating the cylinder counterclockwise then pull out. **Discard the old assembly.**

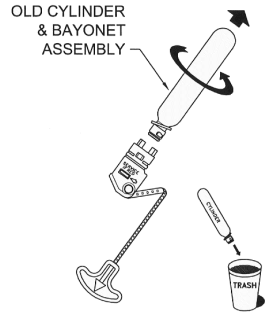

NOTE: Rearming must follow the sequence below and on the next page.

Step 3

Check the new cylinder & bayonet assembly to be sure the sensor ring is not broken, the O-ring is in place, and the cylinder has not been pierced. Do not install assembly if not in proper condition. Refer to Figure 7.

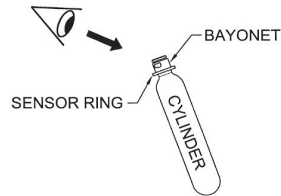

NOTE: The inflator will not allow the installation of an assembly with broken sensor ring.

Step 4

Push and hold the manual lever in place against the inflator.



Figure 6A

Step 5

Install a new cylinder & bayonet assembly by (A) engaging the tabs on the bayonet into the housing, pushing in firmly, then (B) turning clockwise 1/8 turn to a full stop.

Check the bayonet viewport. One of the black bayonet tabs will be entirely visible through the viewport. If a red or white indicator is displayed or the tab is not fully visible, the cylinder & bayonet assembly is not completely installed and needs to be turned clockwise further to a full stop.



WARNING: PFD WILL ONLY INFLATE IF THE CYLINDER & BAYONET ASSEMBLY IS TURNED TO A FULL STOP.

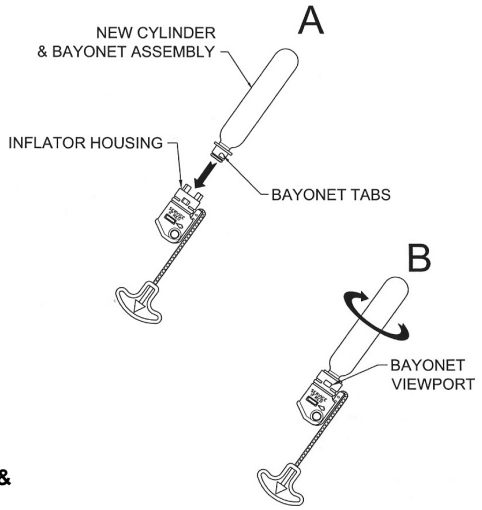

Step 6

Check to be sure the service indicator is GREEN.

Step 7

Refold the PFD (see Section 6.8) and place back into Belt Pack so that the GREEN service indicator is visible through the clear

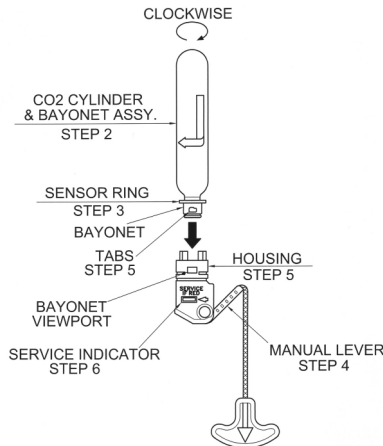
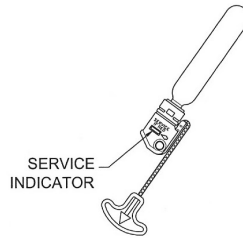

Figure 6B

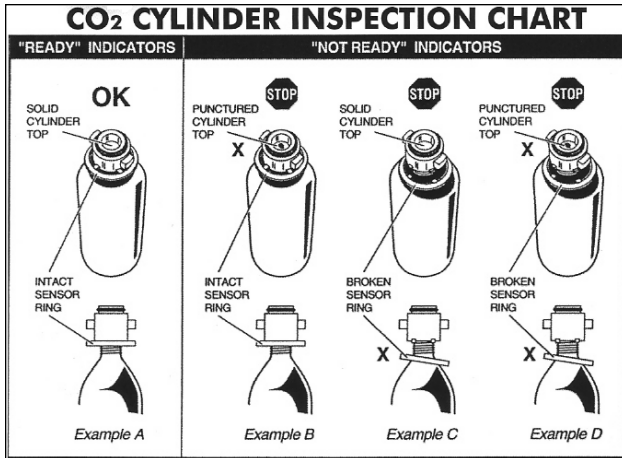
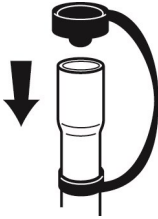

Figure 7

6.8 Refolding Your PFD

Before packing, completely deflate PFD and re-arm cylinder. Refer to Section 6.5, *Deflating Your PFD*, for additional instructions on deflating your PFD. Read thoroughly then complete each step in Figures 8A and 8B.



TO DEFLATE

Press down on oral tube. Squeeze ALL air from bladder.

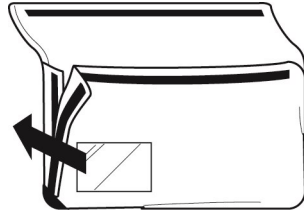

STEP 1

Close side of bag using Velcro®

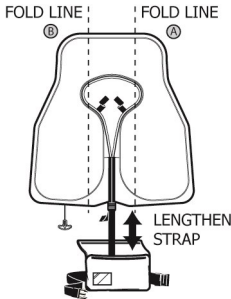

STEP 2

Lay the PFD out flat with the cylinder and oral tube face down. Fully lengthen center adjustment strap.

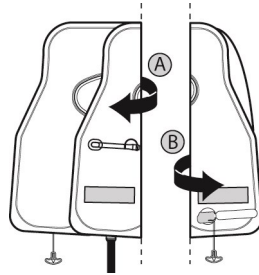

STEP 3

Ⓐ Fold the right side of the PFD over so oral tube is visible, as shown. Ⓑ Fold left side over so cylinder is visible, as shown.

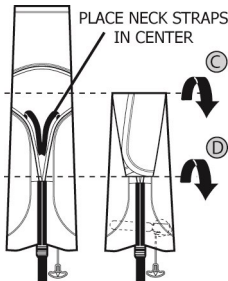

STEP 4

Turn PFD over so the cylinder is face down. Starting from the top, fold down twice. Ⓒ & Ⓓ

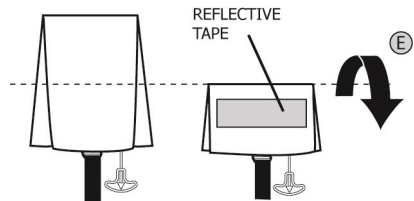

STEP 5

Fold in half so reflective tape in facing upwards. Ⓔ

Figure 8A

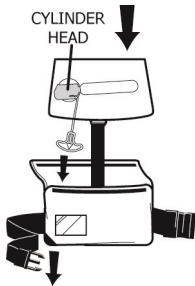

STEP 6

Flip folded PFD chamber over so cylinder is visible. Place folded PFD chamber into pouch so the cylinder head is visible through the window. Gently slide yellow "Jerk" tab through bottom hole, as shown.



STEP 7

Store all labels in pouch. Close pouch using the Velcro® along the length of the pouch.

Figure 8B

7.0 Is Your PFD in Good and Serviceable Condition?

Check your PFD between outings to be sure that it is properly armed (see Section 6.1.1, *Check for Green "OK" Service Indicator*); that it is free of rips, tears or holes; that all seams are securely sewn; and that the fabric, straps and hardware are still strong. Inspect the inflatable portion of the PFD in accordance with Section 8.0, *Care and Maintenance Instructions*.

8.0 Care and Maintenance Instructions

8.1 Service Test Procedures

Service Test includes leakage test and visual inspection. Perform Service Test at the beginning of each boating season and before any long voyage.

8.1.1 Visual Inspection

Before each outing, open the Belt Pack and unfold the PFD. Check the PFD's inflatable cell looking for rips, tears, holes or punctures that might indicate damage.

8.1.2 Leakage Test

Test the PFD's inflatable cell for leaks at the beginning of each season and at least once every two months afterwards. Inflate the PFD orally until the cell becomes firm. Refer to Section 6.4, *Inflating by Mouth (Oral Inflation)*. Allow the PFD to sit overnight for 16 hours and then check to see if the inflatable cell is still firm. A leaking PFD will have become soft and should not be used.

WARNING: DO NOT USE DAMAGED PFD'S. DISCARD THEM, OR RETURN TO REVERE FOR REPAIR.

8.2 Cleaning

Your PFD is made of materials designed to resist soiling and mildew. If cleaning is required, use mild hand soap and cool water. Rub gently. Do not scrub or use abrasive cleaners.

CAUTION: DO NOT DRY CLEAN, IRON OR MACHINE WASH YOUR PFD. DO NOT USE BLEACH.

8.3 Storage

Store your PFD in a cool, dry, well-ventilated place. A damp or wet PFD should be hung by its collar on a clothesline before storage. Do not store PFD where it can be exposed to chemicals. Do not leave your PFD in direct sunlight or in hot areas for long periods when your boat is not in use. Avoid storing the PFD inflated.

CAUTION: NEVER DRY YOUR PFD ON A HEATER, RADIATOR, OR WITH A DIRECT HEAT SOURCE.

8.4 Professional Servicing

For the location of the nearest REVERE authorized service facility or to obtain full factory service, product literature, rearming kits, or customer assistance for your REVERE COMFORT MAX™ PFD, please contact:

REVERE SURVIVAL INC.
Vest Service Department
5323 Highway Ave.
Jacksonville, Florida 32254 USA
Tel. No.: 904-503-9733
sales@reveresurvival.com
www.reveresurvival.com

9.0 Why are PFD's Required Safety Equipment?

Drownings are the leading cause of fatalities involving recreational boating. A PFD provides flotation to help keep your head above water, help you stay face up in the water, and increases your chances for survival and rescue. Most adults only need an extra 7 to 12 pounds of flotation to keep their heads above water. The proper size PFD will properly support the weight of the wearer.

Since this inflatable PFD does not have inherent buoyancy, it provides flotation only when inflated. Familiarize yourself with the use of this PFD so you know what to do in an emergency.

10.0 How and Why Do You Test Your PFD?

WARNING: PRIOR TO INFLATING PFD WITH CO₂, BE SURE YOU HAVE THE REQUIRED REARMING KIT.

Inflate your PFD and try it out in the water to:

- Make sure it floats you:
 - . Comfortably (when worn properly).
 - . Adequately for expected wave conditions (Body shapes/densities affect performance).
- Make sure it works:
 - . A flow of bubbles should not appear. (see Section 8.1.2, *Leakage Test*).
 - . It should inflate quick and easily.
- Learn how it works by:
 - . Activating the CO₂ inflation system.
 - . Rearming the CO₂ inflation system.
 - . Using the oral inflator tube.

The U.S. Coast Guard recommends that you purchase two rearming kits. One to be used immediately in testing the inflation system (see Sections 10.1) and the other to carry onboard as a spare.

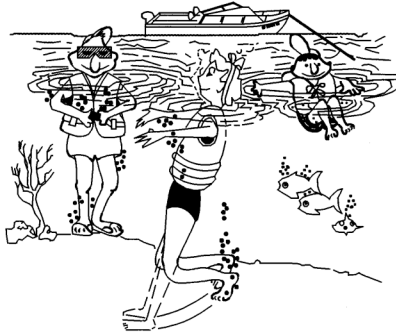

Figure 9

10.1 How Do You Test Your PFD Using the Manual Inflator?

1. To test your inflatable PFD, you will need:
 - Your fully armed PFD, and
 - REVERE Rearming Kit Part No. 61026.
2. Put on the PFD.
3. Actuate the inflation system by jerking firmly downward on the yellow pull-handle. The PFD should fully inflate within 5 seconds.
4. Get into shallow water, just deep enough that you can stand with your head above the surface.

5. See if the PFD will float you on your back or just slightly back of vertical. In a relaxed floating position, verify that your mouth is well above the water's surface. Note the effect of where you hold your legs on how you float.
6. Get out of the water and remove the PFD. Remove the used CO₂ cylinder from the PFD inflator. Completely deflate the PFD using the oral inflator.
7. Let the PFD dry thoroughly. REARM AND REPACK the PFD in accordance with the instructions in Section 6.7 and 6.8!

10.2 How Do You Test Your PFD Using the Oral Inflator?

1. To test your inflatable PFD, you will not need any spare parts, or rearming kits.
2. **Remove the CO₂ cylinder & bayonet assembly, to prevent inadvertent activation of the manual inflation system, which could potentially damage the PFD. Inspect the cylinder & bayonet assembly to ensure it is unused (see Figure 7).**
3. Put on the PFD.
4. Get into shallow water, just deep enough that you can stand with your head above the surface.
5. If you are a weak swimmer or non-swimmer, inflate the PFD partially so that you are supported well enough to be able to complete inflation without touching bottom, either orally or manually. Note this level of inflation because it is the minimum needed for you to safely use this inflatable PFD.
6. Fully inflate the PFD using the oral inflator.
7. See if the PFD will float you on your back or just slightly back of vertical. In a relaxed floating position, verify that your mouth is well above the water's surface. Note the effect of where you hold your legs on how you float.
8. Get out of the water and remove the PFD. Completely deflate the PFD using the oral inflator.
9. Let the PFD dry thoroughly. REARM AND REPACK the PFD in accordance with the instructions in Sections 6.7 and 6.8.

11.0 Wear Your PFD

In approximately 80 percent of all boating fatalities, the victims were not wearing a PFD. Most fatal accidents happen on calm sunny days. This inflatable PFD is much more comfortable to wear than other PFD types. Get into the habit of wearing this PFD. Non-swimmers and children especially should wear a hybrid or non-inflatable PFD at all times when on or near the water.

12.0 Hypothermia

Prolonged exposure to cold water causes a condition known as hypothermia - a substantial loss of body heat, which leads to exhaustion and unconsciousness. Most drowning victims first suffer from hypothermia. The following chart shows the effects of hypothermia:

HOW HYPOTHERMIA AFFECTS MOST ADULTS			
Water Temperature		Exhaustion or Unconsciousness	Expected Time of Survival
°C	°F		
0.3	32.5	Under 15 Min.	Under 15 to 45 Min.
0.3 to 4	32.5 to 40	15 to 30 Min.	30 to 90 Min.
4 to 10	40 to 50	30 to 60 Min.	1 to 3 Hours
10 to 16	50 to 60	1 to 2 Hours	1 to 6 Hours
16 to 21	60 to 70	2 to 7 Hours	2 to 40 Hours
21 to 27	70 to 80	2 to 12 Hours	3 Hours to Indefinite
Over 27	Over 80	Indefinite	Indefinite

PFDs can increase survival time because they allow you to float without using energy treading water and because of their insulating properties. Naturally, the warmer the water, the less insulation you will require. When operating in cold waters [below 60°F (15.6°C)] you should consider using a coat or jacket style PFD or a Type V Thermal Protective PFD as they cover more of the body than the vest or belt style PFDs.

Some Points to Remember about Hypothermia Protection:

1. Always wear your PFD. Even if you become incapacitated due to hypothermia, the PFD will keep you afloat and greatly improve your chances of rescue.
2. Do not attempt to swim unless to reach a nearby craft, fellow survivor, or a floating object on which you can lean or climb. Swimming increases the rate of body heat loss. In cold water, drown proofing method that require putting your head in water are not recommended. Keep your head out of the water. This will greatly lessen heat loss and increase your survival time.
3. Use the standard H.E.L.P. position when wearing an inflatable PFD. Wrap your arms around your torso, under the PFD, and drawing the legs up to a seated position, because doing so will help you conserve body heat.
4. Keep a positive attitude about your survival and rescue. This will improve your chances of extending your survival time until rescued. *Your will-to-live does make a difference!*
5. If there is more than one person in the water, huddling is recommended while waiting to be rescued. This action tends to reduce the rate of heat loss and thus increase the survival time.



Figure 10

13.0 Each of These Devices is Intended to Help You Save Your Own Life

For your PFD to function properly, follow these suggestions to verify that it fits, floats, and remains in good condition.

1. Check the inflation mechanism service indicators before each use.
2. Get in the habit of rearming the inflation mechanism right after each CO₂ inflation.
3. Try your wearable PFD on and adjust it until it fits comfortably in and out of the water.
4. Mark your PFD with your name if you are the only wearer.
5. Do not alter your PFD. It doesn't fit properly get one that does. An altered device is no longer Coast Guard approved.
6. Your PFD is not intended for use as a fender or kneeling pad.
7. If your PFD is wet, allow it to dry thoroughly before storing it. Store it in a well-ventilated area.
8. Do not dry your PFD in front of a radiator or other source of direct heat.

14.0 Additional Information

If you need more information about PFDs and safe recreational boating, contact your state boating authority, U.S. Coast Guard Auxiliary, U.S. Power Squadron, Red Cross, or your nearest unit of the U.S. Coast Guard. To find out about the free boating courses in your area, call 1-800-336-BOAT (in VA, 1-800-245-BOAT) or see the USCG Boating Web Page at www.uscgboating.org.

14.1 Do Not Attach PFD's to Your Boat

Each PFD has straps, hooks, buckles, or other means for securing the device in place on the wearer. Some PFDs also incorporate decorative dee rings or tabs. Such items are not to be used to attach the device to the boat. Attaching the device to the boat will not permit it to perform as intended.

REVERE SURVIVAL INC.

5323 Highway Ave.
Jacksonville, Florida 32254 USA
Tel. No.: 904-503-9733
www.reveresurvival.com